

# EMISSION CONTROL SYSTEM

EC01H-02

## PURPOSE

The emission control systems are installed to reduce the amount of CO, HC and NOx exhausted from the engine ((3) (4) and (5)), to prevent the atmospheric release of blow-by gas-containing HC (1) and evaporated fuel containing HC being released from the fuel tank (2).

The function of each system is shown in these table.

System	Abbreviation	Function
(1) Positive Crankcase Ventilation	PCV	Reduces HC
(2) Evaporative Emission Control	EVAP	Reduces evaporated HC
(3) Warm UP Three-Way Catalytic Converter	WU-TWC	Reduces HC, CO and NOx
(4) Three-Way Catalytic Converter	TWC	Reduces HC, CO and NOx
(5) Sequential Multiport Fuel injection*	SFI	Injects a precisely timed, optimum amount of fuel for reduced exhaust emissions

Remark: \* For inspection and repair of the SFI system, refer to the SF section of this manual.

# PARTS LAYOUT AND SCHEMATIC DRAWING LOCATION

EC011-03

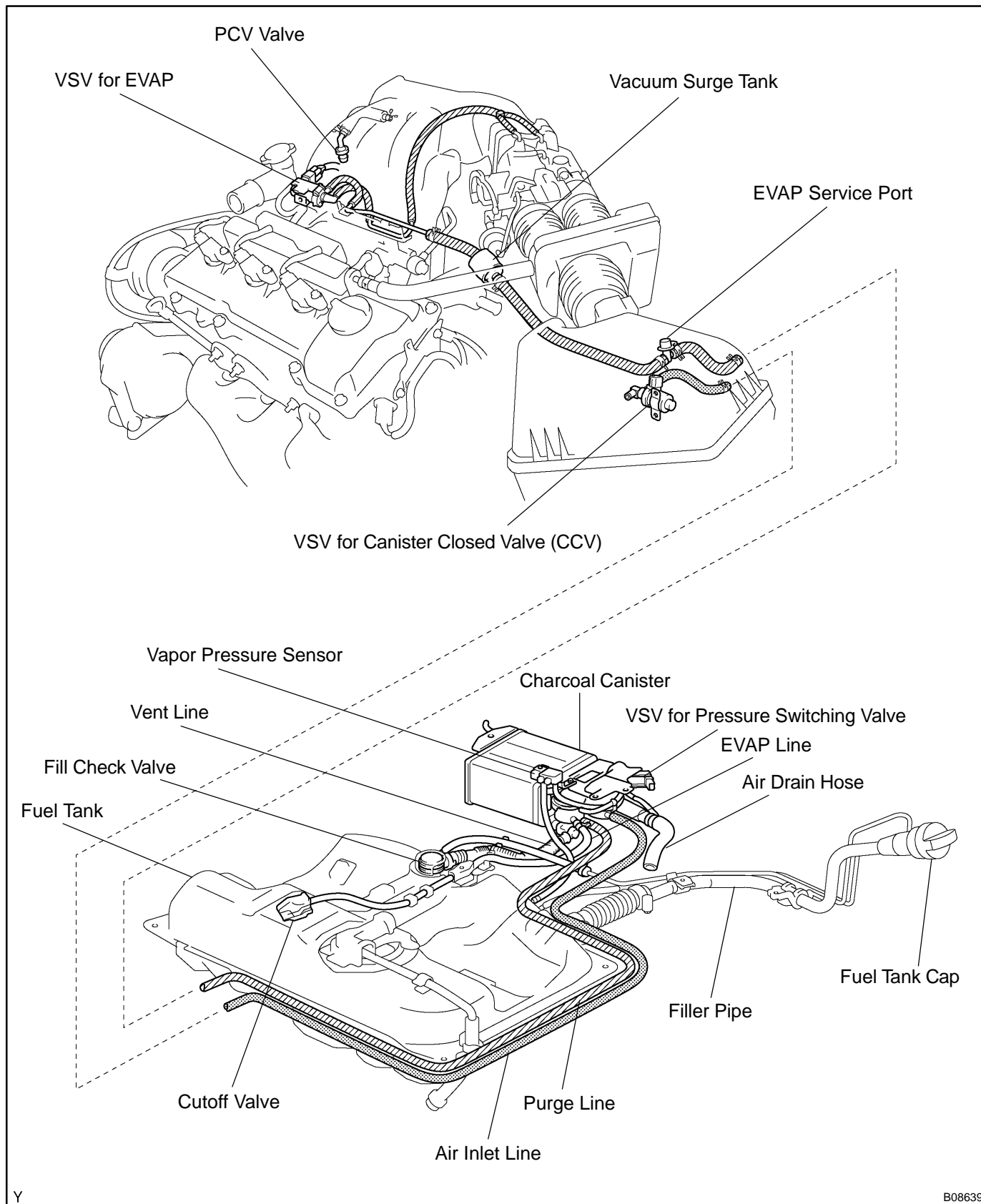

# DRAWING

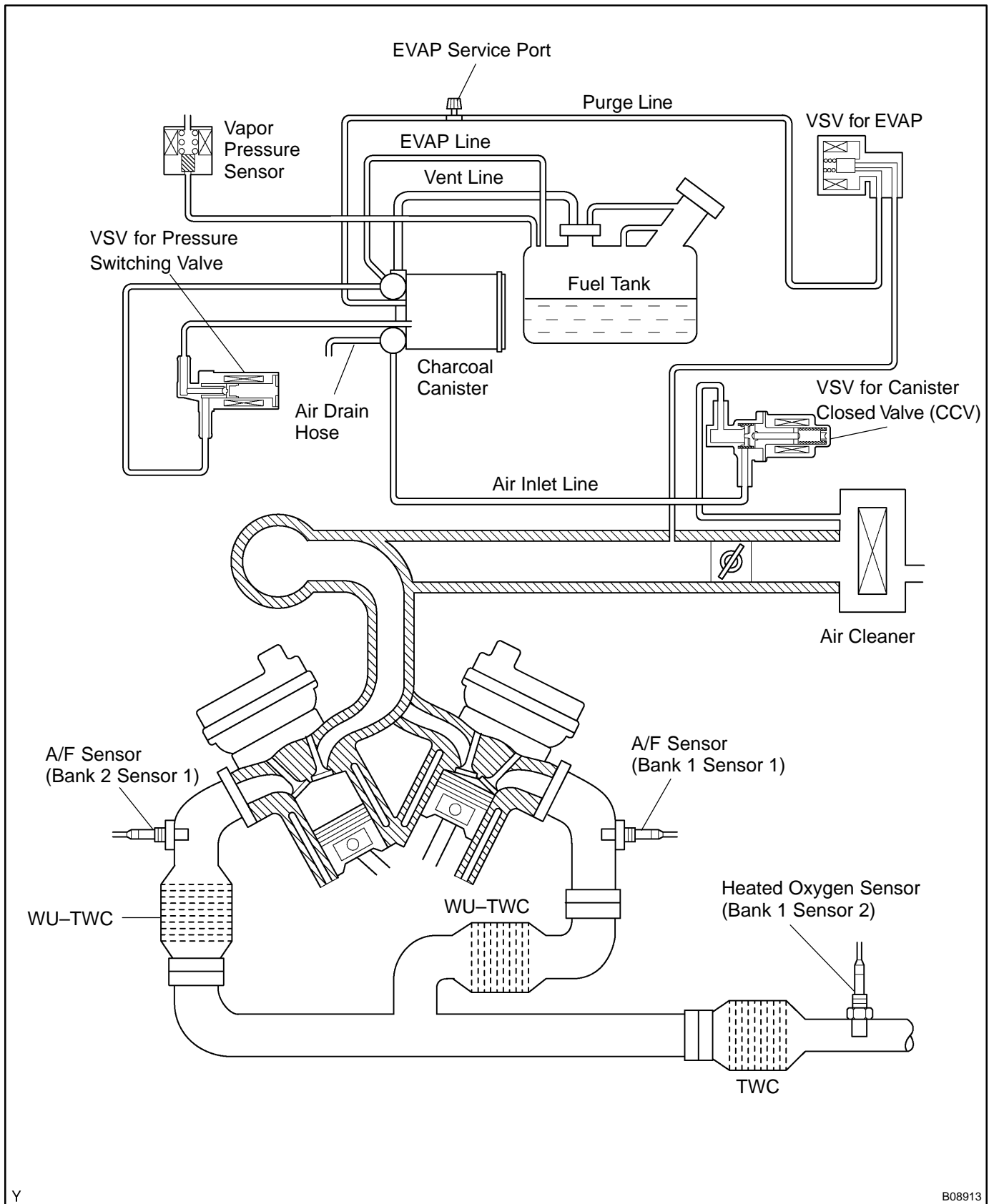

Y

B08913

# POSITIVE CRANKCASE VENTILATION (PCV) SYSTEM INSPECTION

EC0BE-01

## 1. INSPECT PCV VALVE

- (a) Remove the PCV valve.

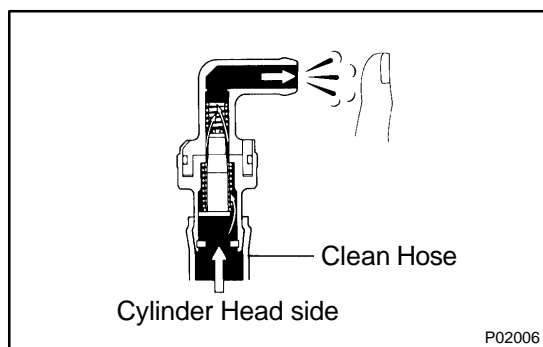

- (b) Install clean hose to the PCV valve.
- (c) Inspect the PCV valve operation.
  - (1) Blow air into the cylinder head side, and check that air passes through easily.

### CAUTION:

**Do not suck air through the valve.**

**Petroleum substances inside the valve are harmful.**

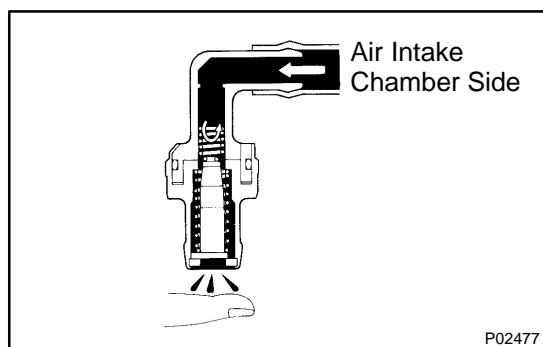

- (2) Blow air into the air intake chamber side, and check that air passes through with difficulty.
- If operation is not as specified, replace the PCV valve.
- (d) Remove clean hose from the PCV valve.
  - (e) Reinstall the PCV valve.

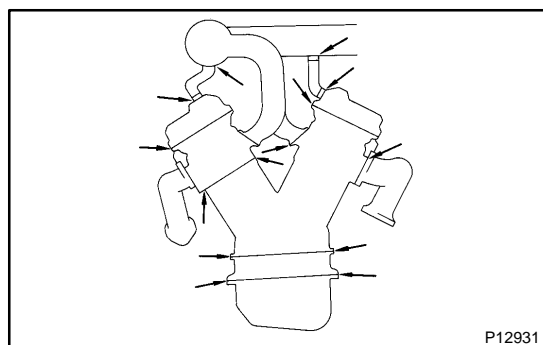

## 2. INSPECT HOSES, CONNECTIONS AND GASKETS

Visually check for cracks, leaks or damage.

# EVAPORATIVE EMISSION (EVAP) CONTROL SYSTEM COMPONENTS

EC0BF-02

## Charcoal Canister

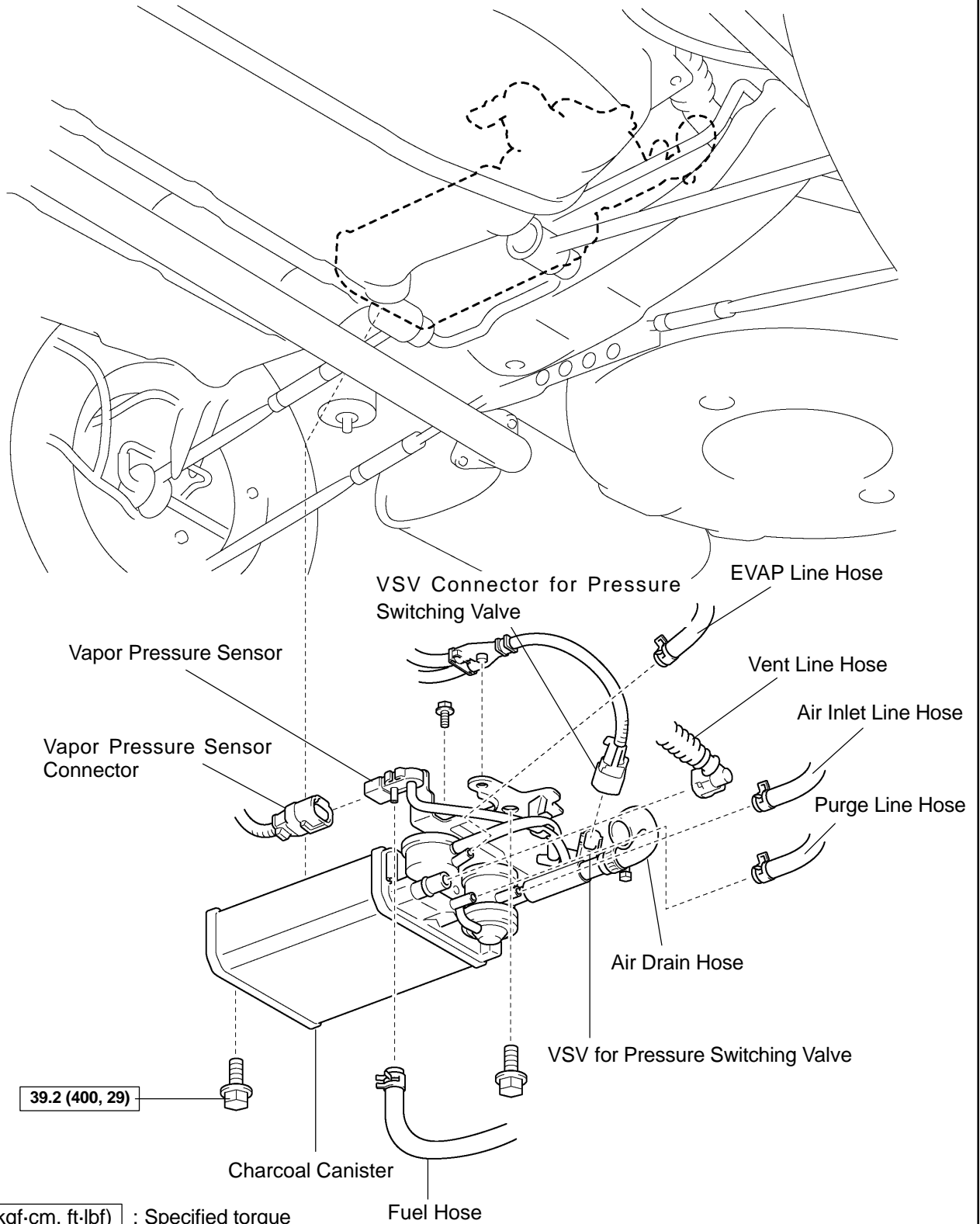

B08627

## INSPECTION

### 1. INSPECT LINES AND CONNECTORS

Visually check for loose connections, sharp bends or damage.

### 2. INSPECT FUEL TANK FILLER PIPE

Visually check for deformation, cracks or fuel leakage.

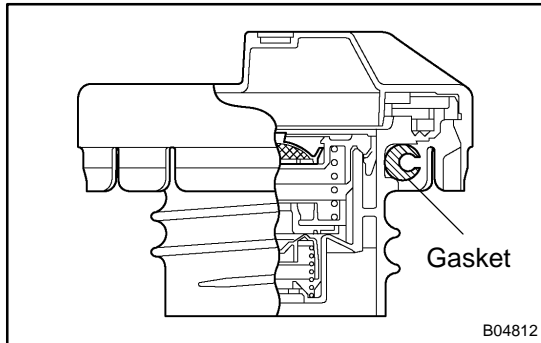

### 3. INSPECT FUEL TANK CAP

Visually check if the cap and/or gasket are deformed or damaged.

If necessary, repair or replace the cap.

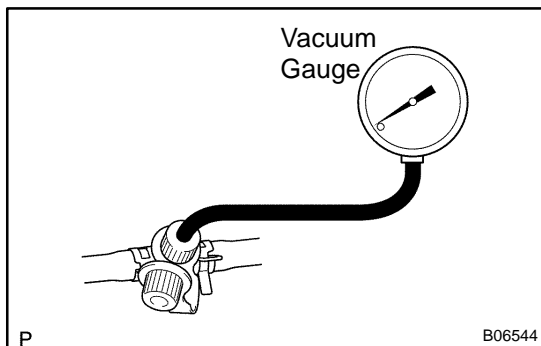

### 4. INSPECT EVAP SYSTEM LINE

(a) Warm up the engine and stop the engine.

Allow the engine to warm up to normal operating temperature.

(b) Install a vacuum gauge (EVAP control system test equipment vacuum gauge) to the EVAP service port on the purge line.

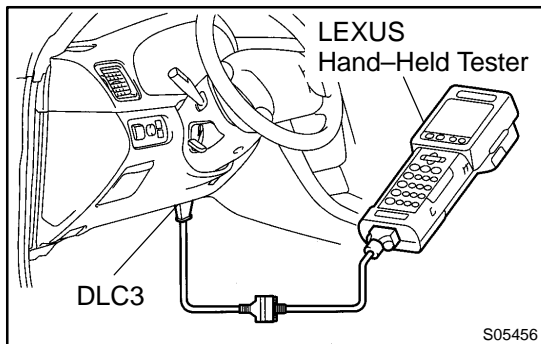

(c) LEXUS Hand-Held Tester:

Forced driving of the VSV for the EVAP.

- (1) Connect a LEXUS hand-held tester to the DLC3.
- (2) Start the engine.
- (3) Push the LEXUS hand-held tester main switch ON.
- (4) Use the ACTIVE TEST mode on the LEXUS hand-held tester to operate the VSV for the EVAP.

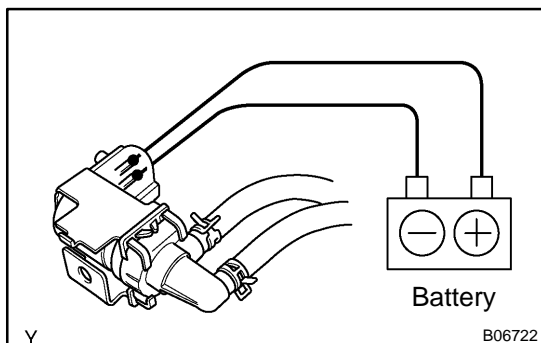

(d) If you have no LEXUS Hand-Held Tester:

Forced driving of the VSV for the EVAP.

- (1) Disconnect the VSV connector for the EVAP.
- (2) Connect the positive (+) and negative (-) leads from the battery to the VSV terminals for the EVAP.
- (3) Start the engine.

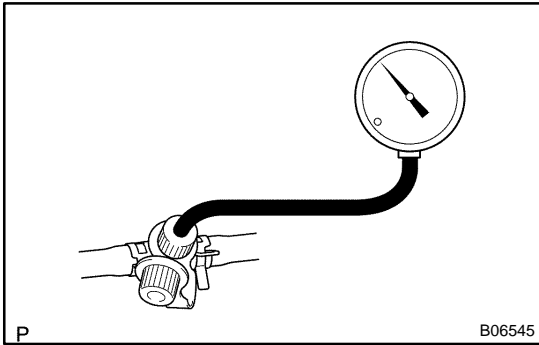

- (e) Check the vacuum at idle.  
**Vacuum:**  
**Maintain at 0.368 – 19.713 in.Hg (5 – 268 in.Aq) for over 5 seconds**

**HINT:**

If the vacuum does not change, you can conclude that the hose connecting the VSV to the service port has come loose or is blocked, or the VSV is malfunctioning.

- (f) LEXUS Hand-Held Tester:  
 Conclude forced driving of the VSV for the EVAP.
  - (1) Stop the engine.
  - (2) Disconnect the LEXUS hand-held tester from the DLC3.
- (g) If you have no LEXUS Hand-Held Tester:  
 Conclude forced driving of the VSV for the EVAP.
  - (1) Stop the engine.
  - (2) Disconnect the positive (+) and negative (-) leads from the battery from the VSV terminals for the EVAP.
  - (3) Connect the VSV connector for the EVAP.
- (h) Disconnect the vacuum gauge from the EVAP service port on the purge line.
- (i) Connect a pressure gauge to the EVAP service port on the purge line.

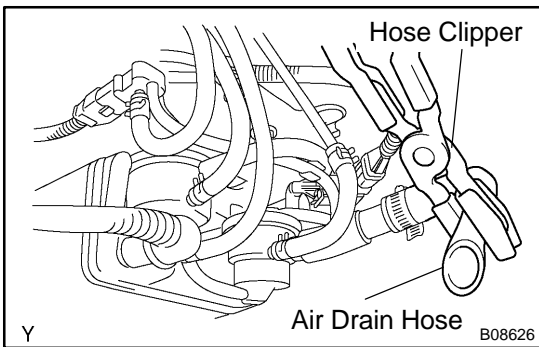

- (j) Check the pressure.
  - (1) Close off the air drain hose at the marked position of the canister with a hose clipper or similar instrument.

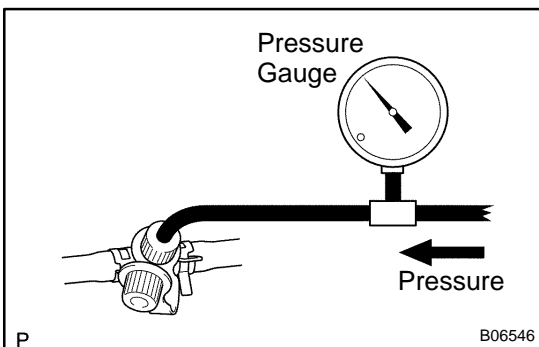

- (2) Add the pressure (13.5 – 15.5 in.Aq) from the EVAP service port.  
**Pressure:**  
**2 minutes after the pressure is added, the gauge should be over 7.7 – 8.8 in.Aq.**

**HINT:**

If you can't add pressure, you can conclude that the hose connecting the VSV ~ canister ~ fuel tank has slipped off or the VSV is open.

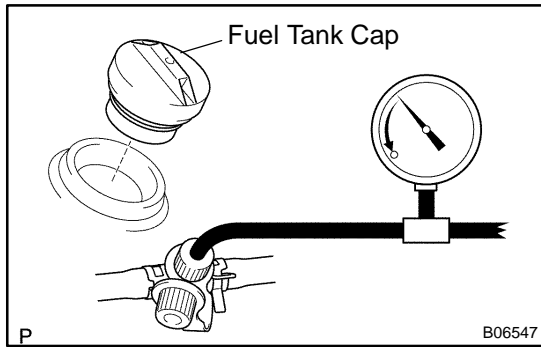

- (3) Check if the pressure decreases when the fuel tank cap is removed while adding pressure.

**HINT:**

If the pressure does not decrease when the filler cap is removed, then you can conclude that the hose connecting the service port to the fuel tank is blocked, etc.

- (k) Disconnect the pressure gauge from the EVAP service port on the purge line.

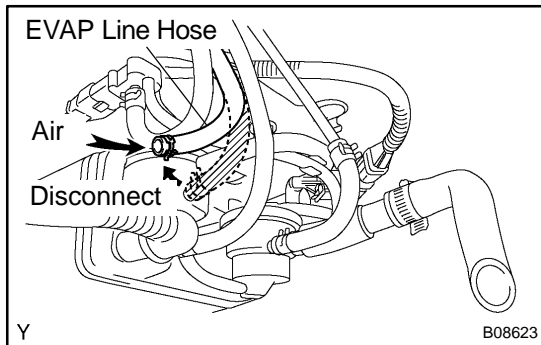

**5. CHECK AIRTIGHTNESS IN FUEL TANK AND FILLER PIPE**

- (a) Disconnect the EVAP line hose from the charcoal canister side and then pressurize and make the internal pressure in the fuel tank 4 kPa (41 gf/cm<sup>2</sup>, 0.58 psi).
- (b) Check that the internal pressure of the fuel tank can be hold for 1 minute.
- (c) Check the connected portions of each hose and pipe.
- (d) Check the installed parts on the fuel tank.

If there is no abnormality, replace the fuel tank and filler pipe.

- (e) Reconnect the EVAP line hose to the charcoal canister.

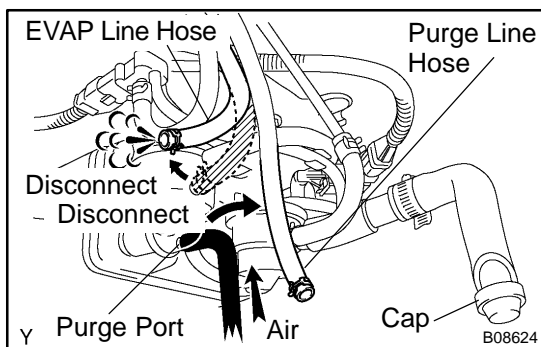

**6. INSPECT FUEL CUTOFF VALVE AND FILL CHECK VALVE**

- (a) Disconnect the purge line hose and EVAP line hose from the charcoal canister.
- (b) Plug the cap to the air drain hose.
- (c) Pressurize 4 kPa (41 gf/cm<sup>2</sup>, 0.58 psi) to the purge port and check that there is ventilation through the EVAP line hose.

**HINT:**

In the condition that the fuel is full, as the float valve of the fill check valve is closed and has no ventilation, it is necessary to check the fuel amount (volume).

- (d) Check if there is any stuck in the vent line hose and EVAP line hose.

If there is no stuck in hoses, replace the fuel cutoff valve and fill check valve.

- (e) Reconnect the purge line hose and EVAP line hose to the charcoal canister.

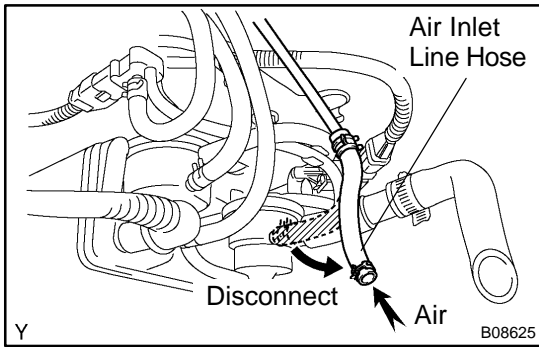

**7. CHECK AIR INLET LINE**

- (a) Disconnect the air inlet line hose from the charcoal canister.
- (b) Check that there is ventilation in the air inlet line.
- (c) Reconnect the air inlet line hose to the charcoal canister.

**8. REMOVE CHARCOAL CANISTER ASSEMBLY**

- (a) Disconnect the VSV connector for pressure switching valve.
- (b) Disconnect the vapor pressure sensor connector.
- (c) Disconnect the fuel hose from the vapor pressure sensor.
- (d) Disconnect the purge line hose, EVAP line hose and air inlet line hose from the charcoal canister.

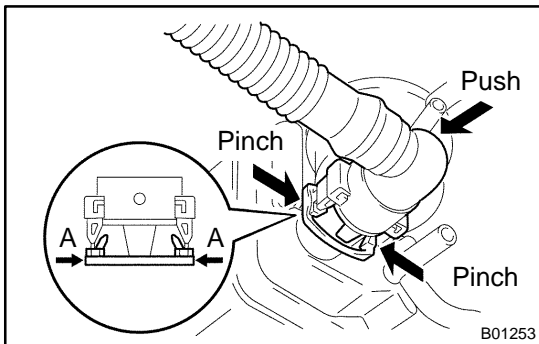

- (e) Disconnect the vent line hose from the charcoal canister.
  - (1) Push the connector deep inside.
  - (2) Pinch portion A.
  - (3) Pull out the connector.
- (f) Remove the 2 charcoal canister mounting bolts.
- (g) Remove the vapor pressure sensor mounting bolt.
- (h) Remove the charcoal canister assembly.

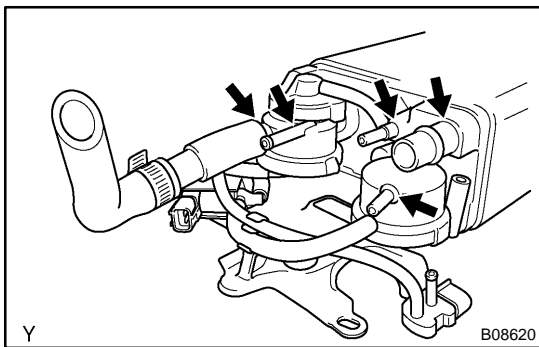

**9. INSPECT CHARCOAL CANISTER**

- (a) Visually check the charcoal canister for cracks or damage.

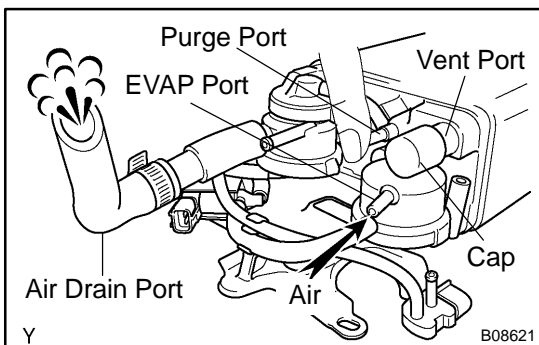

- (b) Inspect the charcoal canister operation.
  - (1) Plug the vent port with a cap.
  - (2) While holding the purge port closed, blow air (1.76 kPa, 18 gf/cm<sup>2</sup>, 0.26 psi) into the EVAP port and check that air flows from the air drain port.

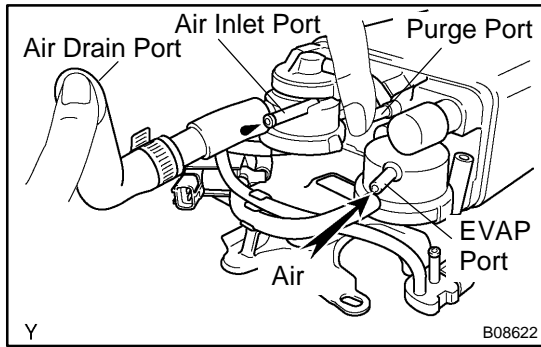

- (3) While holding the purge port and the air drain port closed, blow air (1.76 kPa, 18 gf/cm<sup>2</sup>, 0.26 psi) into the EVAP port and check that air does not flow from the air inlet port.

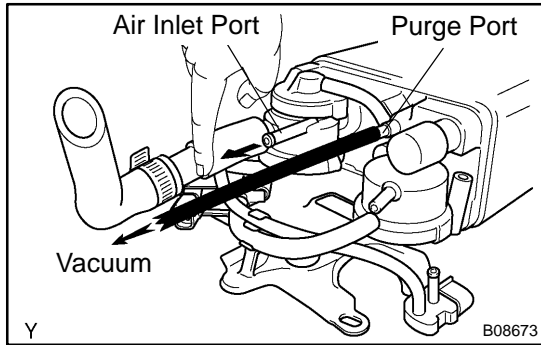

- (4) Apply vacuum (3.43 kPa, 25.7 mmHg, 1.01 in.Hg) to the purge port, check that the vacuum does not decrease when the air inlet port is closed, and check that the vacuum decreases when the air inlet port is released.

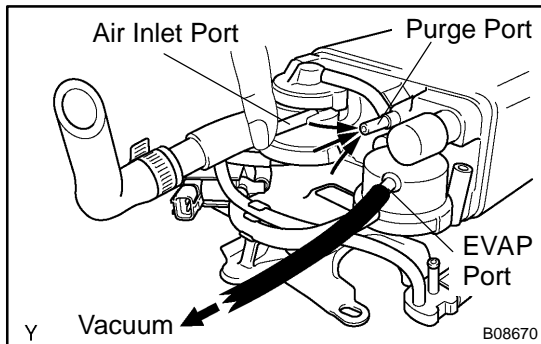

- (5) While holding the air inlet port closed, apply vacuum (3.43 kPa, 25.7 mmHg, 1.01 in.Hg) to the EVAP port and check that air flows into the purge port.

If operation is not as specified, replace the charcoal canister.

- (6) Remove the cap from the vent port.

10. **INSPECT VSV FOR EVAP (See page SF-62)**
11. **INSPECT VSV FOR CANISTER CLOSED VALVE (CCV) (See page SF-67)**
12. **INSPECT VSV FOR PRESSURE SWITCHING VALVE (See page SF-69)**
13. **INSPECT VAPOR PRESSURE SENSOR (See page SF-72)**
14. **REINSTALL CHARCOAL CANISTER ASSEMBLY**

# WARM UP THREE-WAY CATALYTIC CONVERTER (WU-TWC) SYSTEM

EC0BH-01

## ON-VEHICLE INSPECTION

### 1. INSPECT EXHAUST PIPE ASSEMBLY

- (a) Check the connections for looseness or damage.
- (b) Check the clamps for weakness, cracks or damage.

### 2. INSPECT WU-TWC

Check for dents or damage.

If any part of the protector is damaged or dented to the extent that it contacts the WU-TWC, repair or replace it.

### 3. INSPECT WU-TWC HEAT INSULATOR

- (a) Check the heat insulator for damage.
- (b) Check for adequate clearance between the catalytic converter and heat insulator.

# COMPONENTS

## WU-TWC for Bank 1

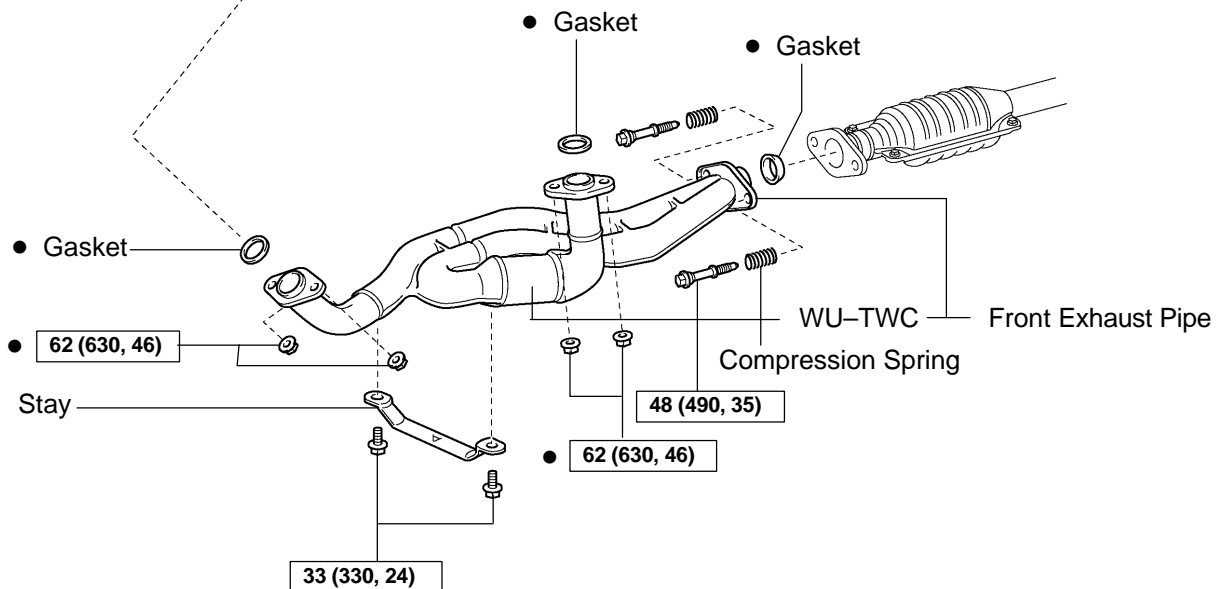
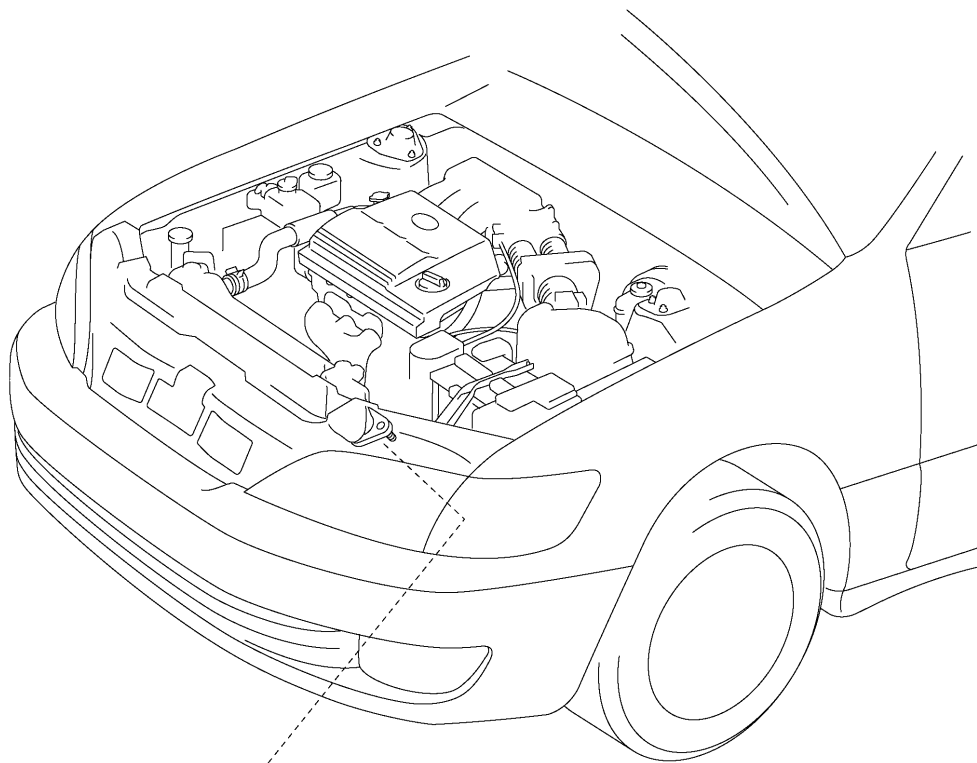

N·m (kgf·cm, ft·lbf) : Specified torque

● Non-reusable part

B06528

WU-TWC for Bank 2

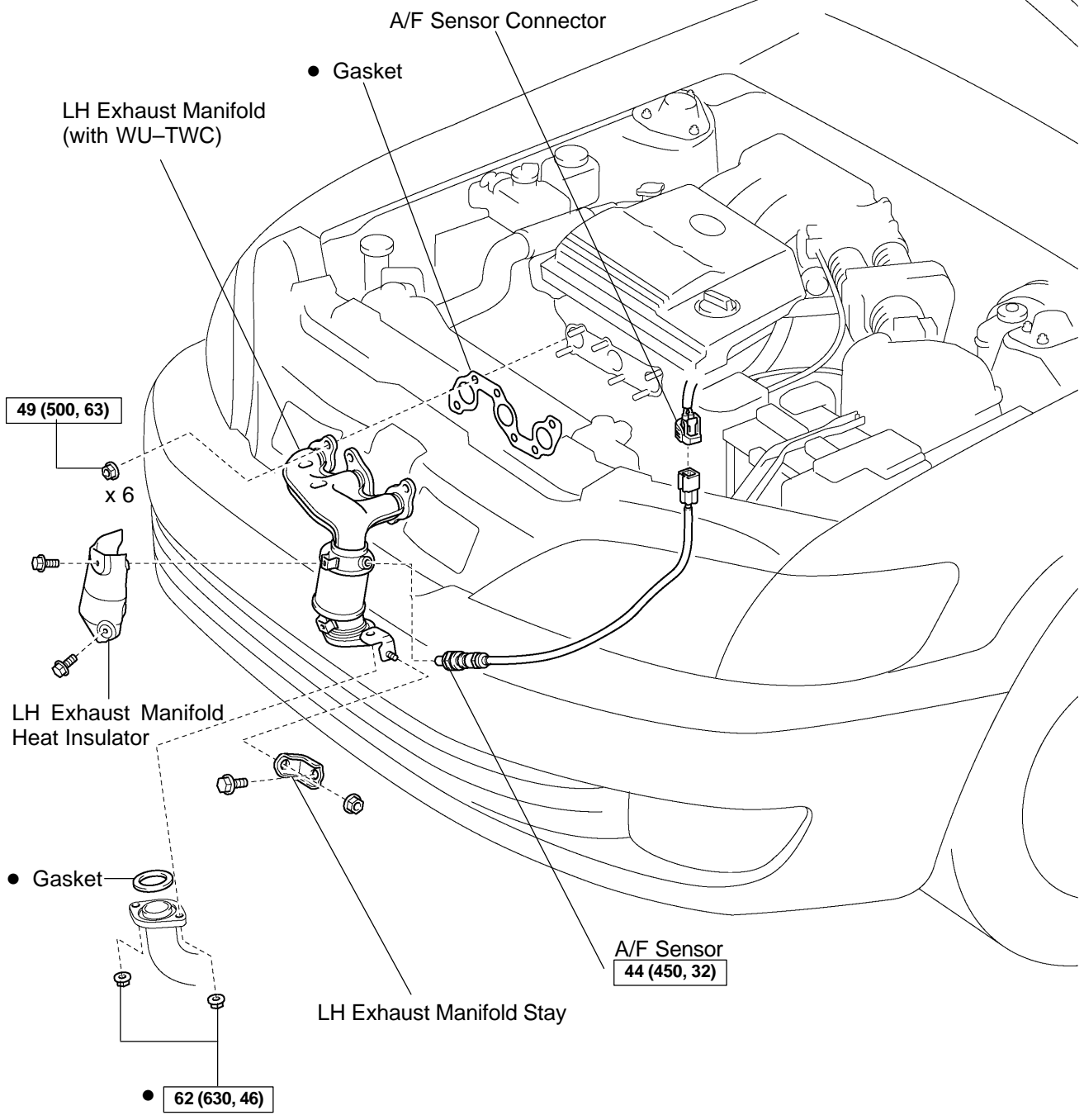

N·m (kgf·cm, ft·lbf) : Specified torque

● Non-reusable part

B06600

## THREE-WAY CATALYTIC CONVERTER (TWC) SYSTEM ON-VEHICLE INSPECTION

EC0BJ-01

### 1. INSPECT EXHAUST PIPE ASSEMBLY

- (a) Check the connections for looseness or damage.
- (b) Check the clamps for weakness, cracks or damage.

### 2. INSPECT TWC

Check for dents or damage.

If any part of the protector is damaged or dented to the extent that it contacts the TWC, repair or replace it.

### 3. INSPECT TWC HEAT INSULATOR

- (a) Check the heat insulator for damage.
- (b) Check for adequate clearance between the catalytic converter and heat insulator.

# COMPONENTS

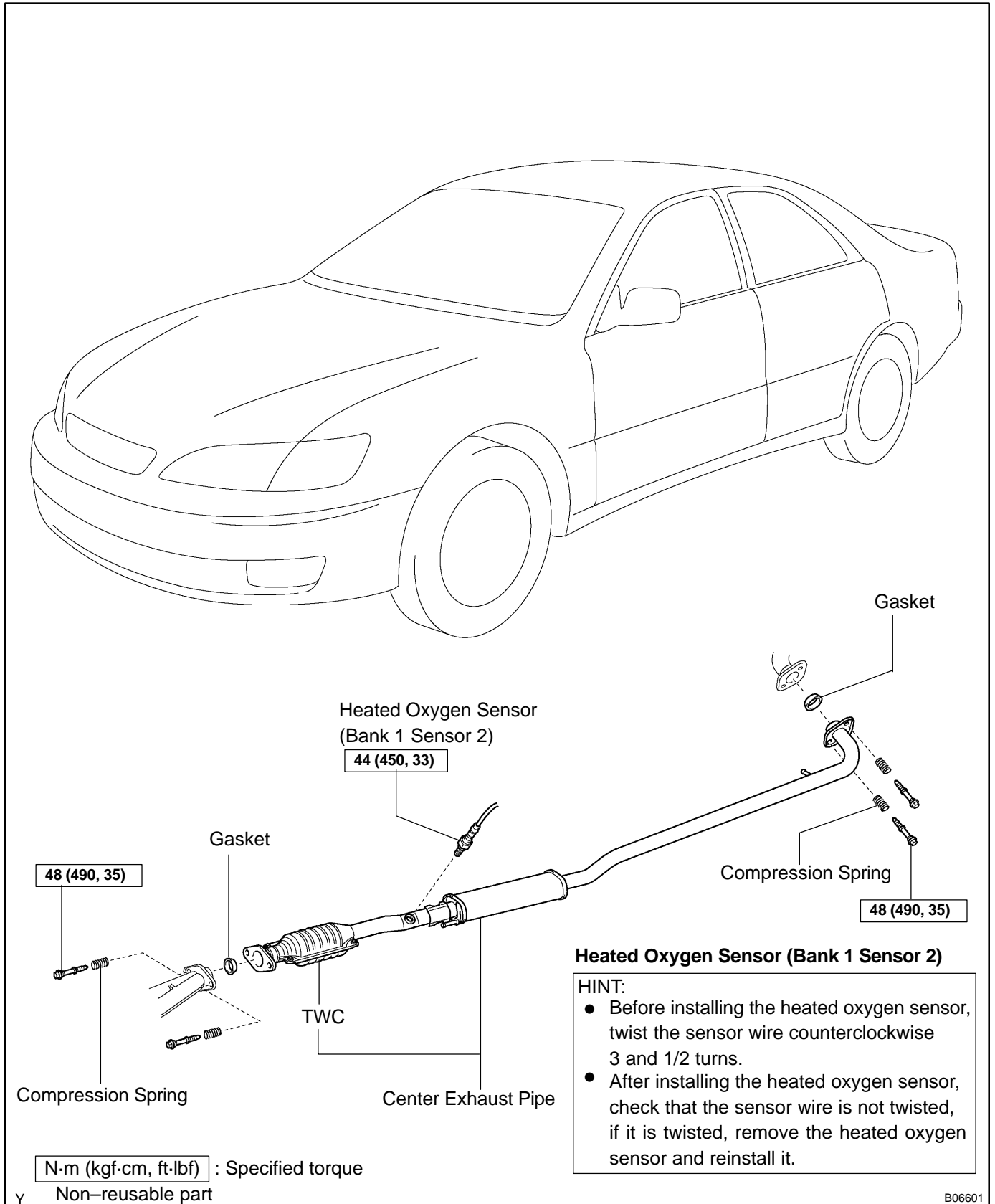

B06601